

WiseCam[®]

Infrared camera for the inspection chamber

Data sheet



Description:

WiseCam is used to determine where there are rodents in the pipe system.

The camera is used before, during and after pest control with WiseTrap and gives the users a clear overview of the situation.

It can also be used to advantage for all other types of surveillance tasks in the sewer.

WiseCam sends out infrared light, and records all activity at the bottom of the inspection chamber in total darkness. It only records when it registers movement.

Its positioning at the top of the well just under the cover makes it easy and fast to get to the camera and to change the memory card, which holds up to 3 days recording.

WiseCam[®]

Infrared camera for the inspection chamber

Data sheet

Control box:

Electronic on/off control.

Inspection Chamber:

From Ø315 mm. Max 5 meter depth.

Installation:

WiseCam 1 is placed on a suspension bar immediately under the well cover and is operated from ground level.

The installation is described the WiseCam Installation Guide enclosed with each camera.

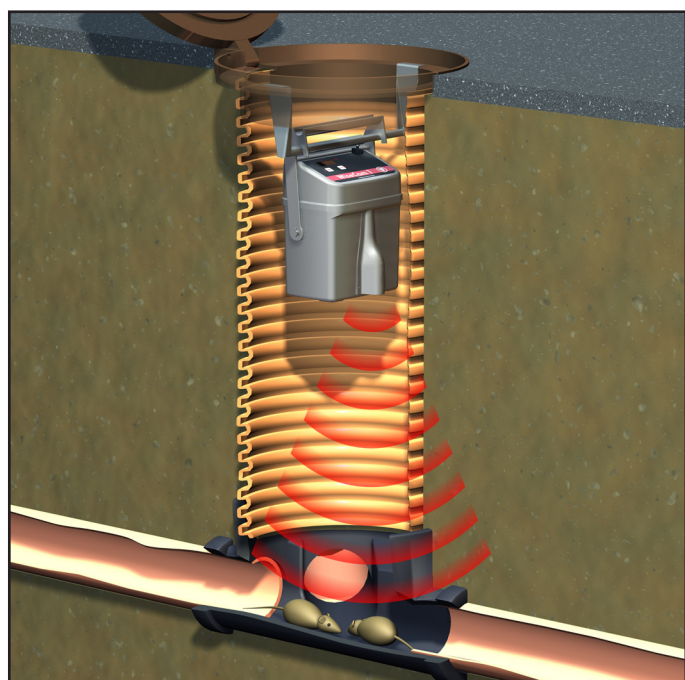

Power supply:

12 Volt battery or power supply 220V / 12 V

Battery capacity:

Approximately 3 days recording.

Supplied with:

1 memory card

Recording registration:

Hard disk with replaceable memory card

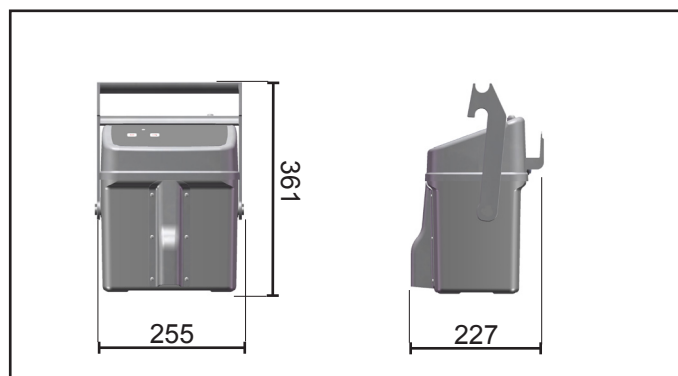

Product description and article no.:

Product description	WiseCam 1
Article no.:	110 000

Weight, excl. battery and suspension bar:

2,0 kg

Ordering information:

- WiseCam product description and article no.
- Suspension bar – see 'Installation equipment'
- Battery – see data sheet 'Accessories'

Remember installation pole, extra batteries and battery charger.